



J2154 PerfectPulse Differential TDR



Documentation

Version 2.0, 2021

Copyright © 2021 Picotest

All Rights Reserved

PerfectPulse is a registered trademark of Picotest.com

Trademarks

The Picotest logo is a trademark of Picotest Corp. “PerfectPulse” and the PerfectPulse logo are trademarks of Picotest Corp.

All other brand and product names mentioned herein are used for identification purposes only and are registered trademarks, trademarks, or service marks of their respective holders.

Copyright notice

Except as permitted under the United States Copyright Act of 1976, no part of this publication may be reproduced or distributed in any form or by any means, or stored in a data base or retrieval system, without the prior written permission of Picotest Corp.

Information in this publication supersedes that in all previously published material. Specifications are subject to change without notice.

Contact information

Corporate offices 1-877 914-PICO

info@picotest.com

<https://www.picotest.com>

Table of Contents

Chapter 1 - Overview	4
Welcome	4
What's Included	7
Documentation and Support	7
Warranty	8
Calibration and Test Board	8
Chapter 2 – Introduction to the PerfectPulse® Signal Generator	9
Introduction and TDR Usage	9
Setting Up TDR Usage	10
FRA Operation	12
VNA Operation	14
Chapter 3 - Specification	15
J2154A PerfectPulse® Specifications	15
Safety Information	15
Handling Information	16
Cleaning	16

Chapter 1 - Overview

Welcome

Thank you for purchasing the PerfectPulse® Differential Time Domain Reflectometry instrument. The J2154A TDR is an ultra-portable signal generator that produces a precise fast edge. The device, packaged in a portable low power, easy to power format supports a wide variety of applications.

It is the perfect tool for signal integrity testing, PCB trace characterization, cable testing, DSP calibration, and Time Domain Reflectometry (TDR) tasks.

J2154A PerfectPulse® Features and Benefits

- Precise Differential or Single-Ended TDR – Time Domain Reflectometry in one convenient package
- All applications requiring a fast, precise edge
- USB or battery powered
- Includes 12GHz internal power splitter for TDR operation
- Compatible with the Picotest P2104A 1-port and P2105A TDR probes, as well as other manufacturers' 50 Ohms probes
- Compatible with most oscilloscopes

J2154A Applications and Usage

- Low-cost PCB coupon tester - Characteristic Impedance PCB traces
- Measure cable and PCB trace length, characteristic impedance, return loss, VSWR, and dielectric constant
- Locate and detect impedance mismatches
- Measure parasitic inductance and capacitance such as bond wires, vias, and ESL

- Verify the integrity of cable crimps and connector launches
- Measure PCB trace path rise/fall time and overshoot/undershoot
- Supports cable and trace loss modeling
- Troubleshoot clock jitter and crosstalk
- Measure microwave filters
- Test the frequency bandwidth, rise/fall time, and flatness of lab instruments and probes

J2154A – How It Works

An internal, differential ultra-low jitter oscillator drives an ultra-high-speed CMOS differential pre-driver. The pre-driver drives a differential ECL logic driver.

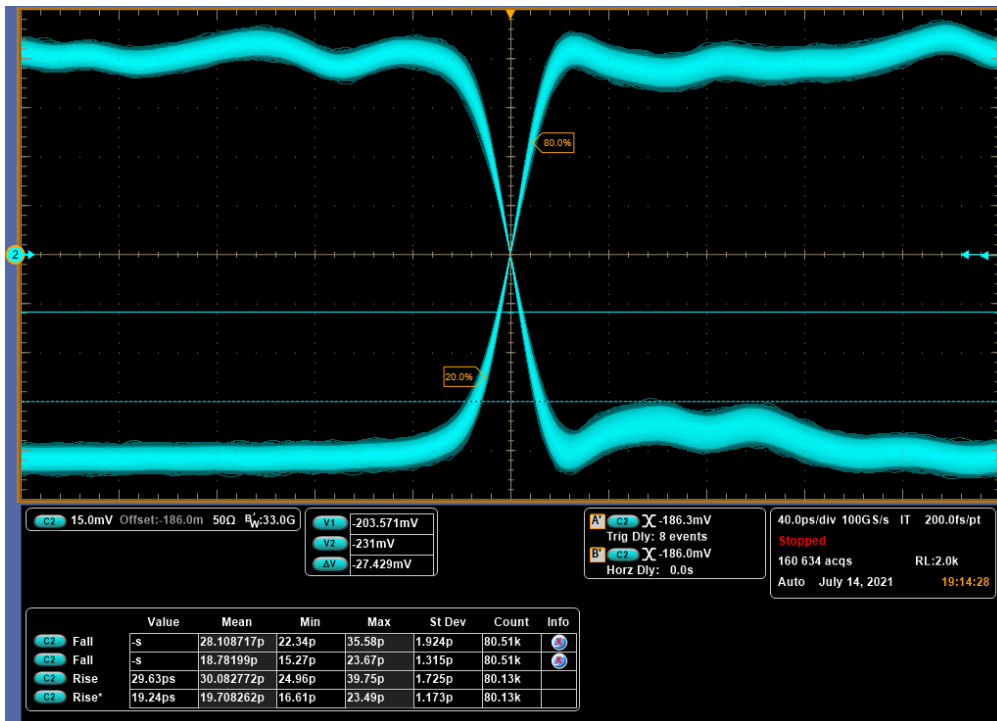

Figure 1: J2154A pulse response.

Internal 6dB resistor power dividers allow scope sampling either before or after 50 Ohm source resistors. With the “VNA” ports connected to the sampler (scope) the FRA/TDR output is sampled at the port. This provides TDR and FRA functionality.

Flipping the TDR to connect FRA/TDR to the scope, the sampler is before the 50 Ohm source resistor. This provides RF VNA functionality.



Figure 2: The J2154A can be connected to support TDR and Frequency Response functions, as well as Vector Network Analysis (VNA) functions (as detailed below).

What's Included

Your Picotest PerfectPulse J2154A Signal Generator includes the following:

- J2154A PerfectPulse Signal Generator and Carrying Case
- TDR Demo board
- BNC-SMA PDN cables
- USB-C Power Cable

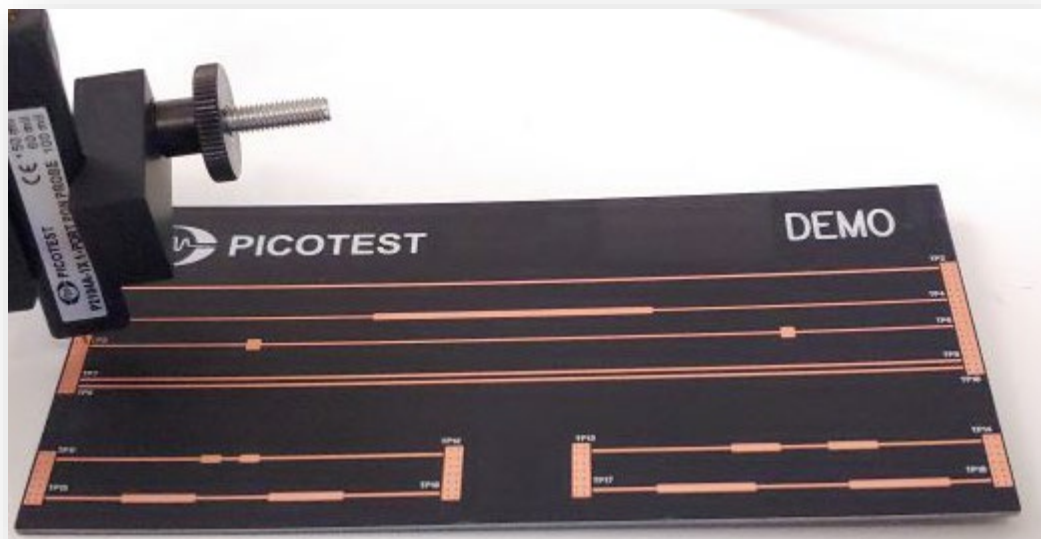

Figure 3: The J2154A comes with a test/demo board which has single and differential test traces with impedance changes at different distances.

Documentation and Support

This documentation details the use the J2154A for various types of measurements. Specifications are also included.

The support section of Picotest's web site, <https://www.picotest.com/support.html>, contains set files that support the J2154A TDR usage on various oscilloscopes.

Warranty

Every Picotest product you buy from Picotest.com is backed by a 1-year manufacturer's warranty. For warranty service or repair this product must be returned to a service facility designated by PICOTEST. Please contact your local service representative for further assistance.

Calibration and Test Board

The PerfectPulse Signal Generator does not require calibration.

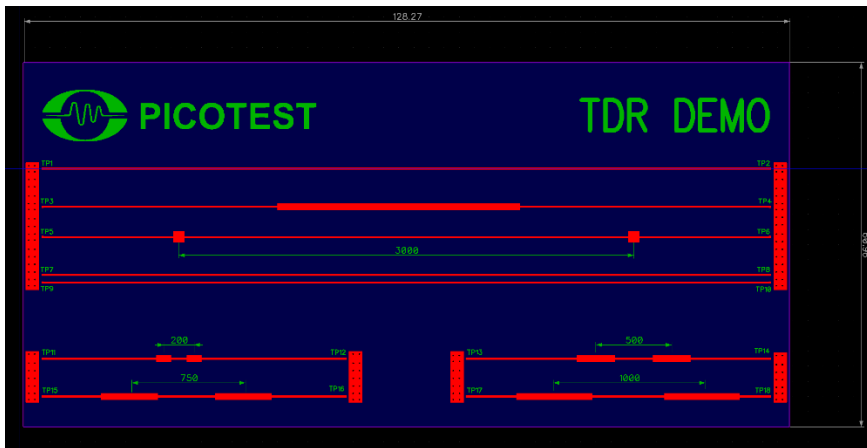

Figure 4: The J2154A demo board.

- Trace 1 (TP1/TP2) – Single ended 50 Ohm trace
- Trace 2 (TP3/TP4) – Single ended OhmBeatty standard
- Trace 3 (TP5/TP6) – Single ended trace with two impedance steps 3000 mils apart
- Trace 4 (TP7/TP9) – Differential 50 Ohm test traces
- Trace 5 (TP11/TP12 and TP15/16) – Differential test traces; one with two impedance steps 200 mils apart and one with two larger discontinuities 750 mils apart
- Trace 6 (TP13/TP14 and TP17/18) – Differential test traces; one with two impedance steps 500 mils apart and one with two larger impedance steps 1000 mils apart

Chapter 2 – Introduction to the PerfectPulse® Signal Generator

Introduction and TDR Usage

The PerfectPulse TDR is a simple to use signal generator designed to support almost any test requirement that can utilize a fast (rising or falling) edge including all TDR applications.

The device is completely self-contained, requiring only a 5V supply from any USB port, including USB battery packs. This allows portable operation.

Power Up the J2154A

Plugging the key into a USB slot starts the operation. There is no need for any other operation.

The J2154A includes a USB-C Cable that you can connect to any standard USB port and to the connector on the J2154A.



Figure 5: The J2154A is powered using a supplied USB cable.

Setting Up TDR Usage

For single-ended and differential mode TDR measurements, Connectors 1 and 3 connect to the oscilloscope channels, while connectors 2 and 4 connect to the probes. This is the native mode and most common mode of operation. These can be either single-ended or differential measurements. Connectors 1 and 2 are used for single-ended measurements.

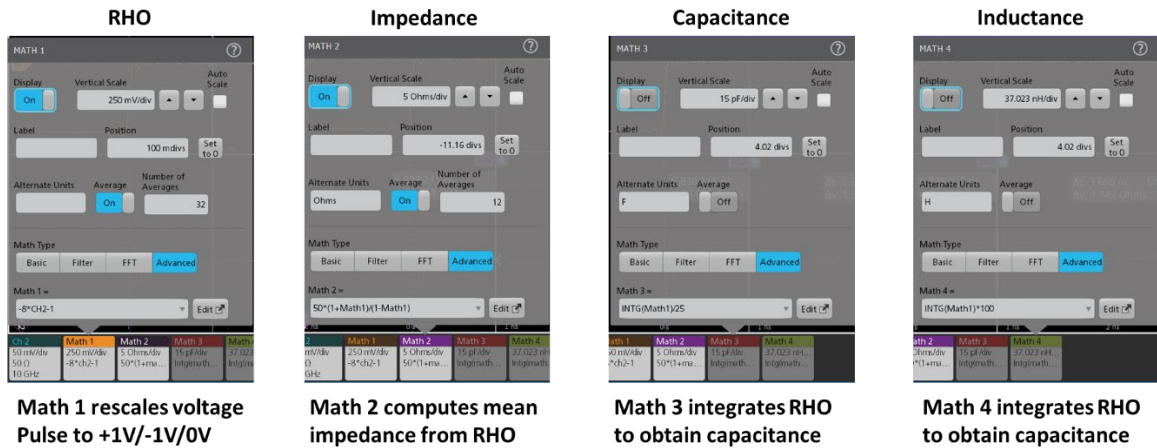

Figure 6: MSO software settings.

RHO rescales J2154A output voltage. Impedance converts from RHO to impedance. The Capacitance equation integrates (the trace step) RHO to obtain the capacitance associated with a step. Inductance integrates (the trace step) RHO to obtain the inductance associated with a step.

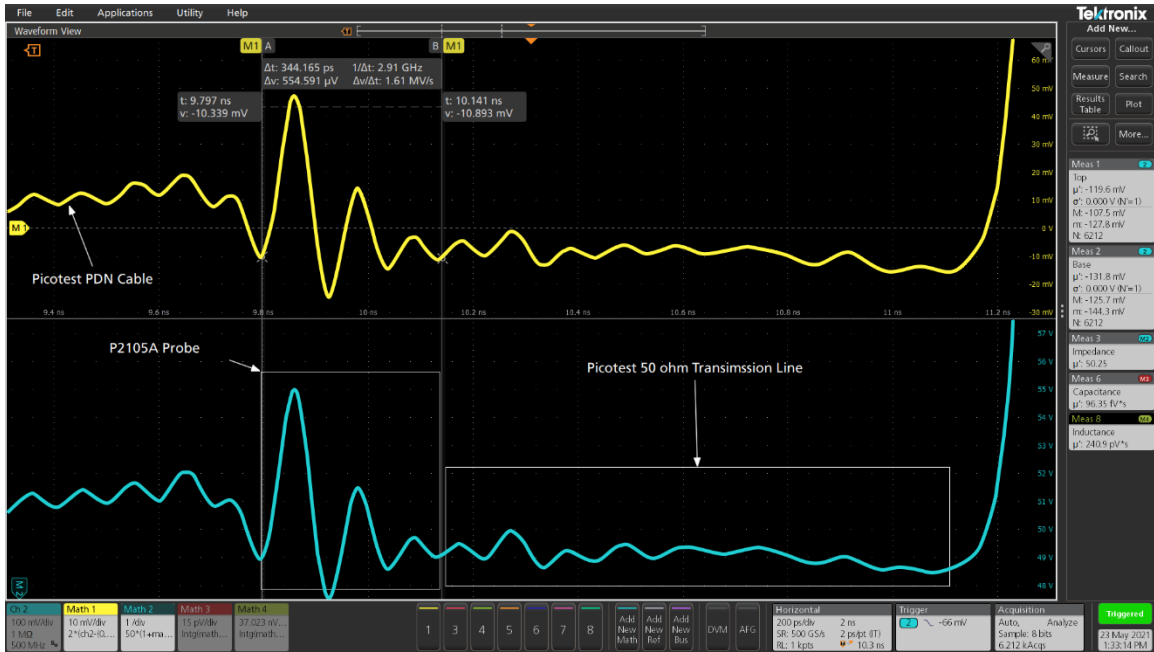

Figure 7: TDR response. The ringing on the left is the Gibbs phenomena, present because in this case the scope bandwidth (10GHz) is LESS than the TDR bandwidth (12GHz). As the scope becomes faster this ringing will disappear. The blip between M1 cursors is the P2105A probe launch. The effective inductance can be seen on the right. The flat portion is the response of a 50ohm transmission line (PCB trace).

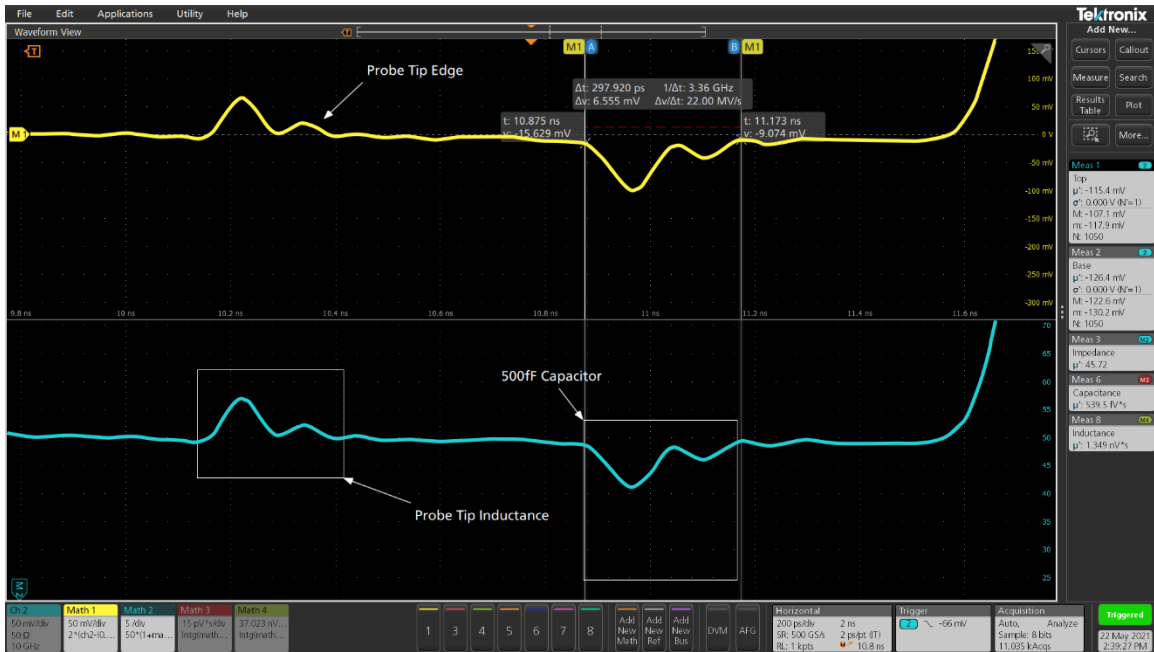

Figure 8: Small value (500fF) capacitor measurement

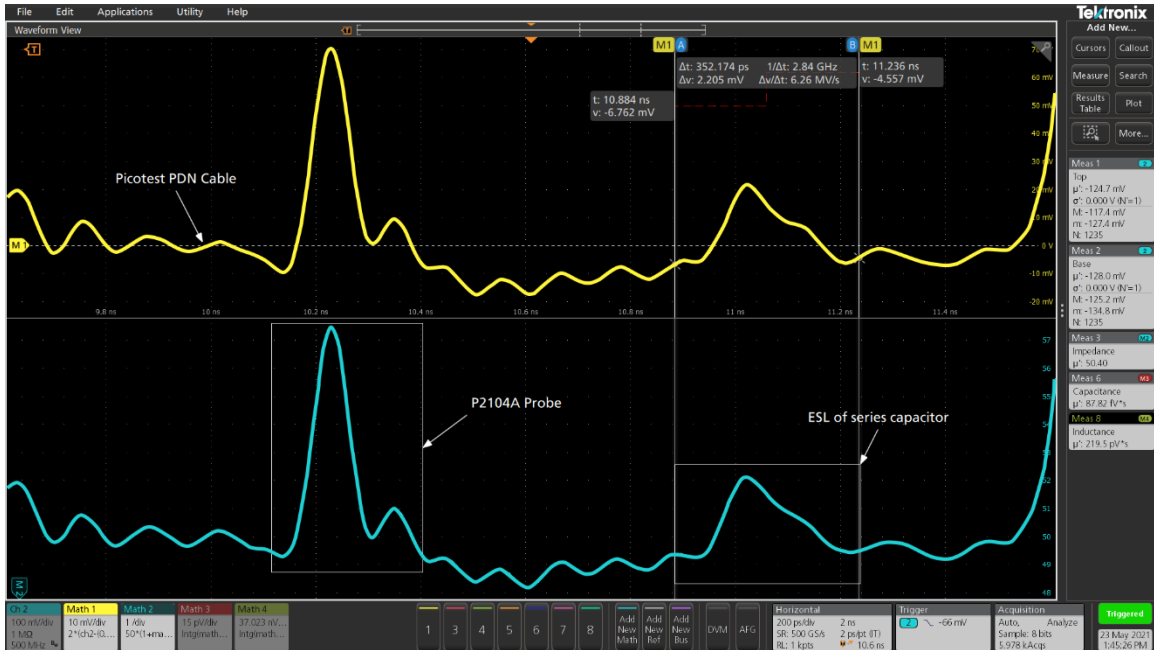

Figure 9: Capacitor ESL inductance measurement

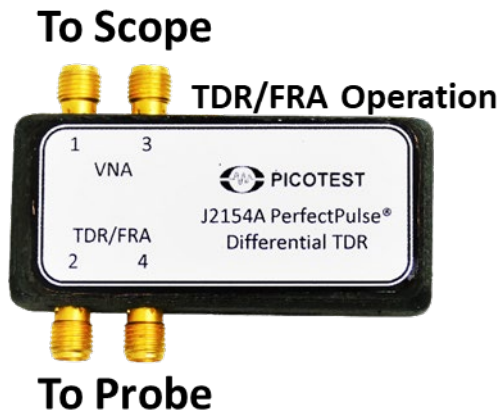

Figure 10: Connections for TDR operation.

FRA Operation

For the measurement of an oscilloscope probe, the voltage is measured at the tip of the probe, so that the 50 Ohm port resistance doesn't damp the probe response. This is equivalent to measuring with a very low source impedance, such as that presented by a power supply. Connectors 1 and 3 connect to the oscilloscope channels, while connectors 2 and 4 connect to the probes. This is the same connection as the TDR, but the math functions use Fast Fourier Transforms (FFTs) of the high-speed signal edge at the tip of the probe and a high or low impedance scope input to measure the back end of the probe to

display the probe transfer function. These can be either single-ended or differential measurements.

A math function provides the FFT of the derivative of the pulse. The result is an impulse that is flat response to the rise/fall time of the pulse (about 13GHz).

Dividing the FFT at the “output” connection by the FFT at the “input” connection results in the transfer function. We can measure the scope, probes, or other devices without the 50 Ohm damping of an S-parameter measurement.

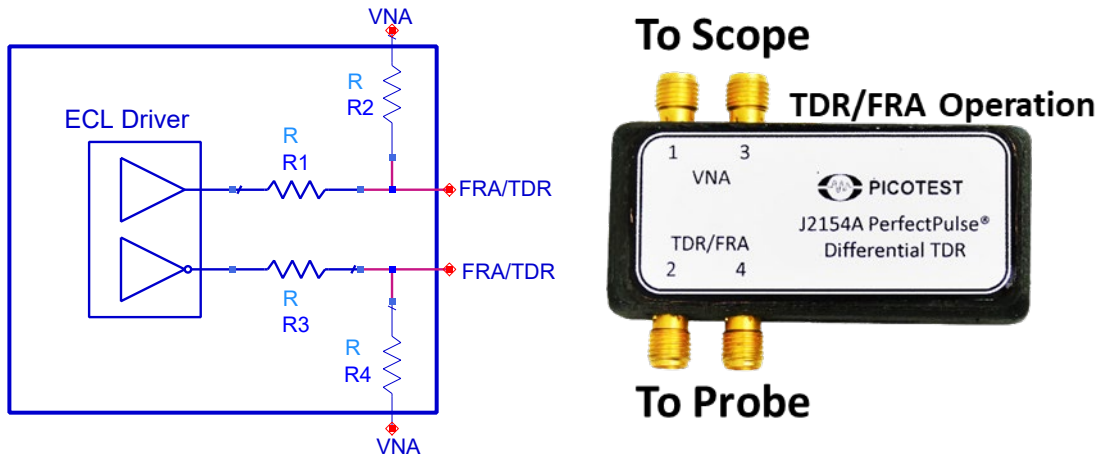

Figure 11: Connections for FRA operation.



VNA Operation

For VNA (frequency domain) measurements the signal is measured prior to the 50 Ohm port resistance so that the output is 50 Ohm as required by S-parameters. This is accomplished by connecting the oscilloscope to connectors 2 and 4 and the probes to connectors 1 and 3. As with the FRA, the math functions use Fast Fourier Transforms (FFTs) of the high-speed signal edge at the probe side as one 50 Ohm port and a second 50 Ohm scope channel as the second port. The math function displays S21. (It is possible also to display S11, but not S22 or S21). These can be either single-ended or differential measurements.

To change the mode:

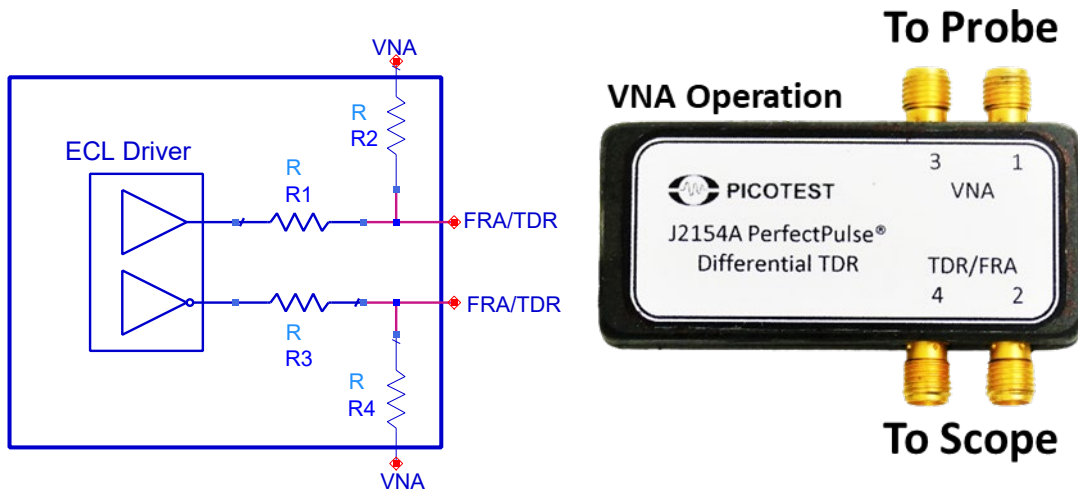

Figure 12: Connections for VNA operation.

Chapter 3 - Specification

Specifications that are not defined to be guaranteed are typical and are published as general information to the user. The instrument should have warmed-up for at least 20 minutes and the environmental conditions should not exceed the unit's specified limits.

J2154A PerfectPulse® Specifications

J2154A	
Characteristic	Rating
Typical rise/fall time	30ps
Power	USB Input
Output Connector	SMA Male
Output Impedance	50 Ohm
Output Voltage	-250mV +/-3mV @ 25C
Flatness	3dB at 10.5GHz 0.1dB (typ.) at 2GHz
Skew output to output	2 psec
Return Loss	typical 55dB max 40dB
Resolution	~164 mils (FR4) *
Operating Temperature	0 to 45° C (32° F to 104° F) at 80% relative humidity

* Dependent on the oscilloscope and probe used



Safety Information

To avoid personal injury and to prevent fire or damage to this product or products connected to it, review and comply with the following safety precautions. Be aware that if you use this key assembly in a manner not specified, the protection this product provides may be impaired. Only qualified personnel should use this key assembly. Do not connect the key to any voltage that exceeds the maximum permissible input voltage specified in the data sheet. Non-compliance with this instruction carries the risk of an electric shock. Make sure not to cause any short circuits when performing measurements on sources with high output currents. Short circuits may cause injuries or burns.

Use only grounded instruments.

Do not connect the key ground (USB connector) to a potential other than ground or earth ground or to any power source that isn't grounded. Always make sure the key and the measurement instrument/power source are grounded properly.

Observe Key ratings.

Do not apply any electrical potential to the key input which exceeds the maximum ratings of the Comb.

Do not operate with suspected failures.

Refer to qualified service personnel.

Indoor use only.

Do not operate in wet/damp environment. Keep product surfaces dry and clean. Do not operate the product in an explosive atmosphere.

Handling Information



Handle with care to avoid any injury. Note that the key cable is a sensitive part of the key and connector. Do not damage through excessive bending or pulling. Avoid mechanical shock to this product in general to guarantee accurate performance and protection.



Caution: To avoid equipment damage and/or severe injuries or death ensure that the absolute maximum ratings defined in this manual are observed at all times and never exceeded.

Cleaning

To clean the exterior of the key, use a soft cloth moistened with either distilled water or isopropyl alcohol. Before use allow the key to dry completely.